

700PW series



www.martekpower.com

Single and Dual Output DC/DC Converter



DESCRIPTIONS

The 700PW series is a family of high density, compact 7.5W DC/DC converter that combine economy with high performance. Eighteen models operate over 2:1 input voltage ranges of 9 to 18, 18 to 36 or 36 to 72VDC; providing single and dual outputs of 5, 12, 15, ± 5 , ± 12 or ± 15 VDC. Standard features include 1000VDC input/output isolation, efficiency as high as 82%, tight line/load regulation and low output ripple and noise. Continuous short circuit protection and internal filter to reduce reflected ripple current are standard. All models are packaged in compact, low profile 1" X 2" X 0.4" inch metal cases.

OUTPUT CHARACTERISTICS

	Min	Typ	Max	Unit/Comments
Output Voltage Accuracy	± 0.5	± 1.0		%; Output voltage at nominal line & FL
Output Voltage Balance				
Dual Outputs	± 0.5	± 2.0		%; Equal Output Loads
Line Regulation				
Single Outputs			± 0.5	% ¹
Dual Outputs			± 1.0	% ¹
Load Regulation				
Single Outputs			± 0.2	% ²
Dual Outputs			± 1.0	% ²
Ripple/Noise				
5V Outputs			75	mV p-p, Nom.Line FL, 20Mhz B.W .using 1 μ f bypass capacitor
12V and 15V Outputs			1	% Vout
Short Circuit Protection				Continuous, Automatic Recovery
Transient Recovery Time		200		μ S to within 1% error band for 25% step load change
Temperature Coefficient		± 0.02		% per $^{\circ}$ C
Over Voltage Protection				See Model Selection Guide

¹ = % Output voltage measured from min. input line to maximum

² = Output voltage measured from FL to 10% Load

FEATURES

- 6 sided Continuous Shielding
- 10W/In³ Power Density
- Wide 2:1 Input Voltage Range
- UL 1950 Approved
- CSA 22.9-950 Approved
- VDE / EN 60950 Approved
- >1,100,000 Hours MTBF

INPUT CHARACTERISTICS

	Min	Typ	Max	Unit/Comments
Input Voltage Range				
12 VDC Input Models	9	12	18	VDC
24 VDC Input Models	18	24	36	VDC
48 VDC Input Models	36	48	72	VDC
Input Fuse Requirements				
12 VDC Input Models		1500		mA, Slow blow type
24 VDC Input Models		750		mA, Slow blow type
48 VDC Input Models		500		mA, Slow blow type
Reflected Ripple Current				See Model Selection Guide
Input Filter				LC Filter

GENERAL CHARACTERISTICS

	Min	Typ	Max	Unit/Comments
Switching Frequency	100			kHz
Isolation Voltage	1000			VDC, 1 minute
Isolation Resistance	1000			Mohm, 500VDC
Isolation Capacitance		80		pF, 100kHz, 1Volt
MTBF (MIL-HBK-217F)	1.1			Million Hours, +25 $^{\circ}$ C, Ground Benign

ENVIRONMENTAL SPECIFICATIONS

	Min	Typ	Max	Unit/Comments
Operating Temp. Range	-40		+75	°C; Ambient
Storage Temp. Range	-40		+125	°C
Relative Humidity			95	% Humidity; non-condensing
Cooling				Free-Air Convection

PHYSICAL CHARACTERISTICS

	Unit/Comments
Case Size	1.0 X 2.0 X 0.4 inches (25.5 X 51.0 X 10.2 mm)
Case Material	Coated Metal with Non-Conductive Base
Shield Connection	
12V and 24V Input Models	Negative Input, Pin 2
48V Input Models	Positive Input, Pin 3
Flammability	UL94V-0
Weight	42.5 Grams

OUTLINE DRAWING

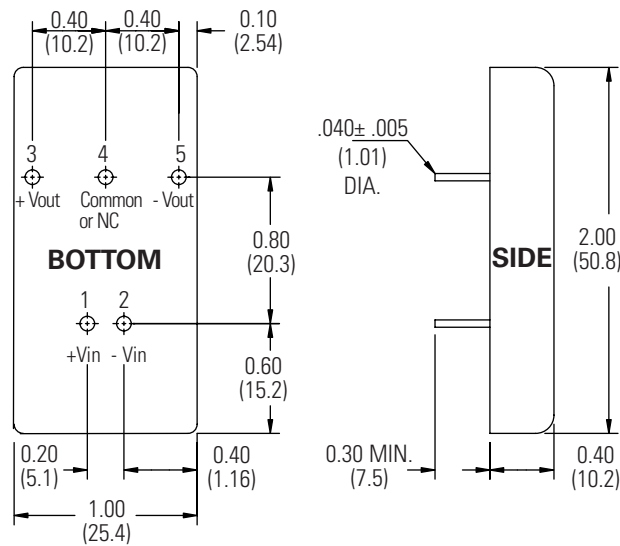

PIN OUT CHART

Pins	Single	Dual
1	+ Vin	+ Vin
2	- Vin	- Vin
3	+ Vout	+ Vout
4	NC	Common
5	- Vout	- Vout

NC = No Connection

Notes:

1. Unless otherwise specified dimensions are in inches (mm).

Tolerances	Inches	mm
	X.XX = ±0.02	X.X = ±0.5
	X.XXX = ±0.010	X.XX = ±0.25

All specifications are typical at nominal input, nominal load and 25° C unless otherwise specified. External, low ESR, 10 microfarad (minimum) capacitor across input is recommended for operation.

How To ORDER

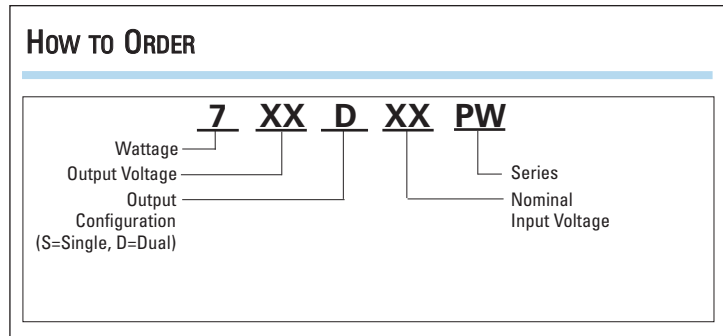

MODEL SELECTION CHART

Model	Nominal Input Voltage (VDC)	Output Voltage (VDC)	Full Load Output Current (mA)	No Load Input Current (mA)	Full Load Input Current (mA)	Reflected Ripple Current (mA)	Output Over Voltage (VDC)	Efficiency @ FL (%)
705S12PW	12	5	1500	46	791	120	6.8	79
712S12PW	12	12	625	46	791	120	15	79
715S12PW	12	15	500	46	791	120	18	79
705D12PW	12	±5	±750	46	791	120	±6.8	79
712D12PW	12	±12	±313	46	783	120	±15	80
715D12PW	12	±15	±250	46	783	120	±18	80
705S24PW	24	5	1500	50	386	60	6.8	81
712S24PW	24	12	625	50	386	60	15	81
715S24PW	24	15	500	50	386	60	18	81
705D24PW	24	±5	±750	50	382	60	±6.8	82
712D24PW	24	±12	±313	50	382	60	±15	82
715D24PW	24	±15	±250	50	382	60	±18	82
705S48PW	48	5	1500	40	198	30	6.8	79
712S48PW	48	12	625	40	198	30	15	79
715S48PW	48	15	500	40	198	30	18	79
705D48PW	48	±5	±750	40	204	30	±6.8	78
712D48PW	48	±12	±313	40	198	30	±15	79
715D48PW	48	±15	±250	40	198	30	±18	79