

1600 series



www.martekpower.com

Single, Dual, Triple Output DC/DC Converter



DESCRIPTIONS

The 1600 series 16 watts high performance DC/DC converters are cost effective solution to the high reliability and performance requirements of power distribution systems in applications ranging from high speed data communications equipment to industrial robotic systems. The 1600 series operates from wide (2:1) input voltage ranges of 9 to 18, 18 to 36 or 36 to 72VDC; providing single, dual and triple output combinations of 5, 12, 15, ± 5 , ± 12 , ± 15 , $5/\pm 12$ and $5/\pm 15$ VDC. All models are packaged in compact, low profile 2" X 2" X 0.4" metal cases.

OUTPUT CHARACTERISTICS

	Min	Typ	Max	Unit/Comments
Output Voltage Accuracy				
Single & Dual Outputs			± 1.0	% ¹
Triple Outputs - Primary			± 1.0	% ¹
- Auxiliaries			± 7.0	% ¹
Output Voltage Adjustment			± 5.0	% ¹
Voltage Balance:				
Dual Outputs			± 1.0	%; Equal Output Loads
Triple Outputs (Auxiliaries)			± 1.0	%; Equal Output Loads
Minimum Load			10%	Full Load
Line Regulation				
Single & Dual Outputs			± 0.5	% ²
Triple Outputs - Primary			± 0.5	% ²
- Auxiliaries			5.0	% ²
Load Regulation				
Single Outputs			± 0.5	% ³
Dual Outputs			± 1.0	% ³ ; Equal Loads
Triple Outputs - Primary			± 0.5	% ³
- Auxiliaries			± 5.0	% ³ ; Equal Loads
Ripple/Noise				
5V Outputs		75		mV p-p, Nom.Line FL, 20Mhz B.W .using 1 μ f bypass capacitor
12V and 15V Outputs		1		% of Vout
Short Circuit Protection				Continuous, Automatic Recovery
Transient Recovery Time		200		μ S to within 1% error band for 50% step load change
Temperature Coefficient			± 0.01	% per °C
Over Voltage Protection				See Model Selection Guide

FEATURES

- 6 sided Continuous Shielding
- Synchronization
- 10.6W/In³ Power Density
- Wide 2:1 Input Voltage Range
- Efficiency to 82%
- UL 1950 Approved
- CSA 22.9-950 Approved
- VDE / EN 60950 Approved

INPUT CHARACTERISTICS

	Min	Typ	Max	Unit/Comments
Input Voltage Range				
12 VDC Input Models	9	12	18	VDC
24 VDC Input Models	18	24	36	VDC
48 VDC Input Models	36	48	72	VDC
Remote On / OFF Control				
Supply ON				5.5 VDC or Open Circuit
Supply OFF				0 VDC to 0.8 VDC
Logic Referenced to Negative Input				
Reverse Polarity Input Current			12	Amp
Input Filter				Pi Filter
Input Fuse Rating				See Model Selection Guide

GENERAL CHARACTERISTICS

	Min	Typ	Max	Unit/Comments
Switching Frequency	100			kHz
Isolation Voltage	1000			VDC, 1 minute
Isolation Resistance	1000			Mohm, 500VDC
Isolation Capacitance		100		pF, 100kHz, 1Volt
MTBF (MIL-HBK-217F)	705			Thousand Hours, +25°C, Ground Benign

¹ = Output voltage at nominal line & FL

² = % Output voltage measured from min. input line to maximum

³ = Output voltage measured from FL to 10% Load

Martek Power reserves the right to change specifications without notice.

ENVIRONMENTAL SPECIFICATIONS

	Min	Typ	Max	Unit/Comments
Operating Temp. Range (Industrial)	-40		+71	°C; Ambient
Storage Temp. Range	-55		+125	°C; Ambient
Relative Humidity		95		% Humidity; non-condensing
Cooling				Free-Air Convection

PHYSICAL CHARACTERISTICS

	Unit/Comments
Case Size	2.0 X 2.0 X 0.4 inches (51.0 X 51.0 X 10.2 mm)
Case Material	Coated Metal with Non-Conductive Base
Shield Connection	
12V and 24V Input Models	Negative Input, Pin 3
48V Input Models	Positive Input, Pin 4
Flammability	UL94V-0
Weight	79 Grams

OUTLINE DRAWING

CASE A

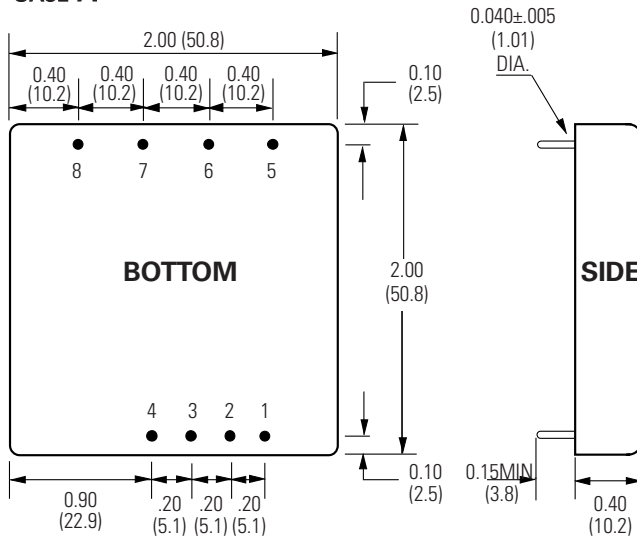

PIN OUT CHART; CASE A

Pin	Single	Dual	Triple
1	Remote On/Off	Remote On/Off	Remote On/Off
2	Sync	Sync	Sync
3	- Vin	- Vin	- Vin
4	+ Vin	+ Vin	+ Vin
5	Trim	Trim	- Vout (Aux)
6	- Vout	- Vout	Common
7	+ Vout	Common	+5V Vout
8	No Pin	+ Vout	+Vout (Aux)

CASE A2

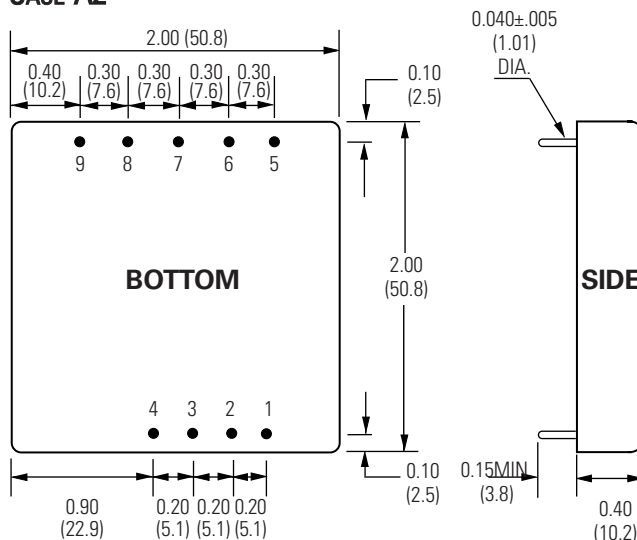

PIN OUT CHART; CASE A2

Pins	3.3V	Triple
1	Remote On/Off	Remote On/Off
2	Sync	Sync
3	- Vin	- Vin
4	+ Vin	+ Vin
5	Trim	- Output (Aux)
6	- Vout	Common (Aux)
7	- Vout	- 5Vout
8	+ Vout	+5V Vout
9	+ Vout	+Vout (Aux)

Notes:

1. Unless otherwise specified dimensions are in inches (mm).

Tolerances	Inches	mm
	X.XX = ±0.02	X.X = ±0.5
	X.XXX = ±0.010	X.XX = ±0.25

All specifications are typical at nominal input, nominal load and 25° C unless otherwise specified. External, low ESR, 10 microfarad (minimum) capacitor across input is recommended for operation.

How To ORDER

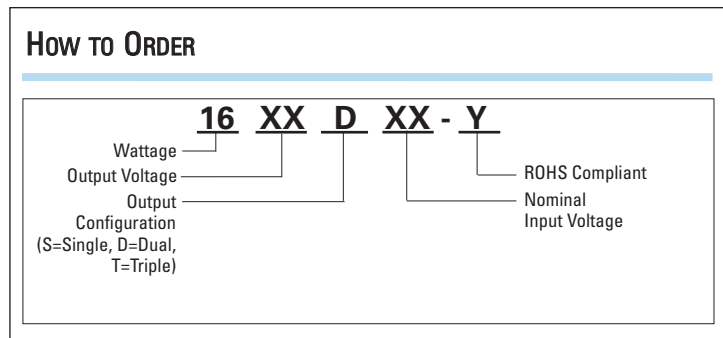

MODEL SELECTION CHART

Model	Nominal Input Voltage (VDC)	Output Voltage (VDC)	Full Load Output Current (mA)	No Load Input Current (mA)	Full Load Input Current (mA)	Output Over Voltage (VDC)	Fuse (A)	Efficiency (%)
1603S12-A2	12	3.3	4850	45	1827	4.7	4.0	78
1605S12	12	5	3200	45	1667	6.8	3.0	80
1612S12	12	12	1300	45	1640	15	3.0	81
1615S12	12	15	1060	45	1650	18	3.0	81
1605D12	12	±5	±1600	45	1667	±6.8	3.0	80
1612D12	12	±12	±665	45	1640	±15.0	3.0	81
1615D12	12	±15	±535	45	1650	±18.0	3.0	81
1603S24-A2	24	3.3	4850	45	890	4.7	2.0	78
1605S24	24	5	3200	35	833	6.8	2.0	80
1612S24	24	12	1300	35	810	15.0	2.0	82
1615S24	24	15	1060	35	815	18.0	2.0	82
1605D24	24	±5	±1600	35	833	±6.8	2.0	80
1612D24	24	±12	±665	35	810	±15.0	2.0	82
1615D24	24	±15	±535	35	815	±18.0	2.0	82
1603S48-A2	48	3.3	4850	45	438	4.7	1.0	78
1605S48	48	5	3200	35	411	6.8	1.0	81
1612S48	48	12	1300	35	405	15.0	1.0	82
1615S48	48	15	1060	35	408	18.0	1.0	82
1605D48	48	±5	±1600	35	411	±6.8	1.0	81
1612D48	48	±12	±665	35	405	±15.0	1.0	82
1615D48	48	±15	±535	35	408	±18.0	1.0	82
1605/12T12	12	5, ±12	2000, ±250	50	1667	6.8, ±15.0	3.0	75
1605/15T12	12	5, ±15	2000, ±200	50	1667	6.8, ±18.0	3.0	79
1605/12T24	24	5, ±12	2000, ±250	45	832	6.8, ±15.0	2.0	81
1605/15T24	24	5, ±15	2000, ±200	45	832	6.8, ±18.0	2.0	75
1605/12T48	48	5, ±12	2000, ±250	35	406	6.8, ±15.0	1.0	79
1605/15T48	48	5, ±15	2000, ±200	35	401	6.8, ±18.0	1.0	81